

JN-85 E

Standard Model

- Modular designed Aluminum alloy arch, easy to assemble and disassemble.
- Auto strap positioning and retry feeding functions enable operating of humanity.
- Convenient operating modes with panel, ball switch and foot pedal switch.
- Internal electricity is 24V accessing, prevent operators from shocking.
- with CKD frame and powder painting on frame.
- Change color on iron arch cover, front doors & frame is available. (Optional)

Specifications

Arch Size	850W x 600H mm (Standard)
Power Supply	110/220V 50/60Hz 1Ph; 220/380V 50/60Hz 3Ph
Strap Cycle Speed	28 Cycles/ 60Hz, 26 cycles/ 50Hz per Min
Tension Strength	Max. 70kgs
Strap Width	6~15.5mm
Sealing Method	Heat Sealing
Dimensions	1400W x 640D x 1475H mm
Table Height	805mm
Machine Weight	220kgs
Gross Weight	265kgs



JN-85 PSA

Semi-auto Pallet Strapping Machine with Mobile Strap Guide.

- Mobile Strap Guide
- Available for various products on pallet
- Dispenser core inner dia.: Ø200 mm (Standard)
- Mini. package height: H630 mm
- Available for PET strap (Optional)
- Available for Dispenser core inner dia.: Ø406 mm (Optional)

Specifications

Strap guide (Length)	L 1000 mm (Standard)
Power Supply	110V/220V 1 Phase; 220V/380V/415V 3 Phase
Dimension	870W x 540D x 1380H mm
Strap Width	12-15 mm (Change kit and adjustment)
Tension Strength	Max.70 Kg
Sealing Method	Heat Sealing

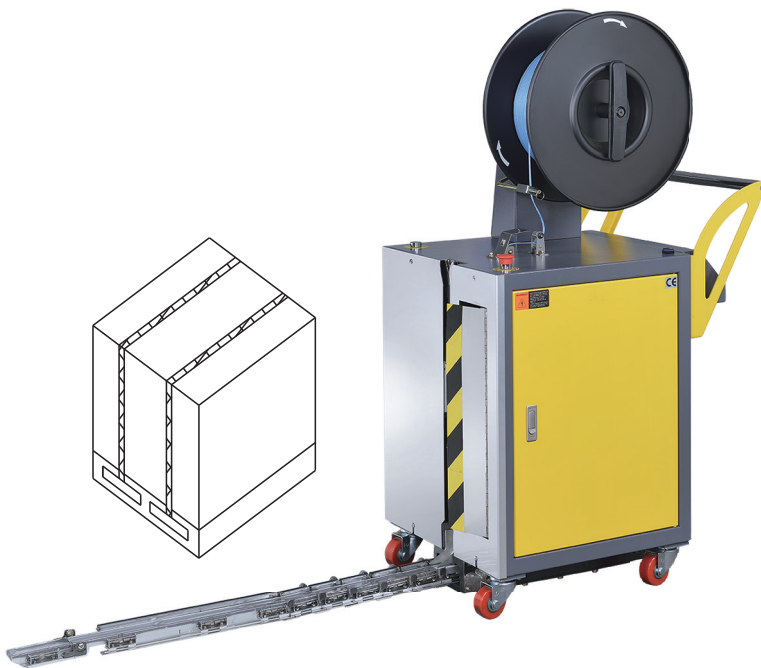

JN-85 PS

- Semi-automatic pallet strapping machine for various requirements when packaging cargo on pallets.
- Moveable design of this model provides convenient operation especially for delicate working places with manual lift where cranes cannot reach.

Specifications

Strap Guide Length	1000mm
Min. Packaging Height	550mm

